

COMPUTING

RTM-ATCA-F120-OPT

Installation and Use

P/N: 6806800G29F

May 2016

ARTESYNTM
EMBEDDED TECHNOLOGIES

© Copyright 2016 Artesyn Embedded Technologies, Inc.
All rights reserved.

Trademarks

Artesyn Embedded Technologies, Artesyn and the Artesyn Embedded Technologies logo are trademarks and service marks of Artesyn Embedded Technologies, Inc. All other names and logos referred to are trade names, trademarks, or registered trademarks of their respective owners. © 2016 Artesyn Embedded Technologies, Inc. All rights reserved. For full legal terms and conditions, please visit www.artesyn.com/legal.

Notice

While reasonable efforts have been made to assure the accuracy of this document, Artesyn assumes no liability resulting from any omissions in this document, or from the use of the information obtained therein. Artesyn reserves the right to revise this document and to make changes from time to time in the content hereof without obligation of Artesyn to notify any person of such revision or changes.

Electronic versions of this material may be read online, downloaded for personal use, or referenced in another document as a URL to an Artesyn website. The text itself may not be published commercially in print or electronic form, edited, translated, or otherwise altered without the permission of Artesyn.

It is possible that this publication may contain reference to or information about Artesyn products (machines and programs), programming, or services that are not available in your country. Such references or information must not be construed to mean that Artesyn intends to announce such Artesyn products, programming, or services in your country.

Limited and Restricted Rights Legend

If the documentation contained herein is supplied, directly or indirectly, to the U.S. Government, the following notice shall apply unless otherwise agreed to in writing by Artesyn.

Use, duplication, or disclosure by the Government is subject to restrictions as set forth in subparagraph (b)(3) of the Rights in Technical Data clause at DFARS 252.227-7013 (Nov. 1995) and of the Rights in Noncommercial Computer Software and Documentation clause at DFARS 252.227-7014 (Jun. 1995).

Contact Address

Artesyn Embedded Technologies
Marketing Communications
2900 S. Diablo Way, Suite 190
Tempe, Arizona 85282

Artesyn Embedded Technologies
Lilienthalstr. 17-19
85579 Neubiberg/Munich
Germany

Contents

About this Manual	9
Safety Notes	13
Sicherheitshinweise	17
1 Introduction	21
1.1 Features	21
1.2 Mechanical Data	22
1.3 Ordering Information	23
2 Hardware Preparation and Installation	25
2.1 Overview	25
2.2 Unpacking and Inspecting the RTM	25
2.3 Environmental and Power Requirements	26
2.3.1 Environmental Requirements	26
2.3.2 Power Requirements	27
2.4 Installing and Removing the RTM	28
2.4.1 Installing the RTM	28
2.4.2 Removing the RTM	33
2.5 Installing and Removing SFP/ SFP+ Modules	35
2.5.1 Installing an SFP/SFP+ Module	37
2.5.2 Removing an SFP/SFP+ Module	39
3 Controls, LEDs and Connectors	41
3.1 Overview	41
3.2 LEDs and Interface Connectors	42
3.2.1 LEDs	43
3.2.2 Interface Connectors	43
3.2.2.1 Fabric Channel Uplinks	44
3.2.2.2 Base Channel Interface Connectors	47
3.2.2.3 SFP/SFP+ Module Hot Swap	50
3.2.2.4 Telecom Clocking Connectors	51

3.2.2.5	Serial Interface Connector	52
4	Functional Description	55
4.1	Overview	55
4.2	Block Diagram	56
4.3	Mezzanine Management Controller	57
A	Related Documentation	63
A.1	Artesyn Embedded Technologies - Embedded Computing Documentation	63

List of Tables

Table 1-1	Mechanical Data	22
Table 2-1	Environmental Requirements	27
Table 3-1	Face Plate LEDs	43
Table 3-2	Fabric Channel 10 GBit Uplink Connectors - Port - MIB OID Assignment	46
Table 3-3	Fabric Channel 1 GBit Uplink Connectors - Port - MIB OID Assignment	47
Table 3-4	Base Channel 10 GBit Uplink Connectors - Port - MIB OID Assignment	49
Table 3-5	Base Channel 1 GBit Uplink Connectors - Port - MIB OID Assignment	50
Table 3-6	Serial Interface - Pinout	54
Table 4-1	IPMI Sensors Overview	57
Table A-1	Artesyn Embedded Technologies - Embedded Computing Publications	63

List of Figures

Figure 1-1	Overview	22
Figure 3-1	Face Plate	42
Figure 3-2	Location of Ethernet Fabric Channel Uplink Interfaces	45
Figure 3-3	Location of Base Interface Uplink Interface Connectors	48
Figure 3-4	Location of Clock Extension Connectors	51
Figure 3-5	Location of Serial Interface Connectors	53
Figure 4-1	Block Diagram	56
Figure 4-2	Location of IPMI Temperature Sensors	60

About this Manual

Overview of Contents

This manual is divided into the following chapters and appendices.

- [Chapter 1, Introduction, on page 21](#) describes the main features of the RTM
- [Chapter 2, Hardware Preparation and Installation, on page 25](#) describes installation prerequisites and the installation itself
- [Chapter 3, Controls, LEDs and Connectors, on page 41](#) describes external interfaces such as connectors and LEDs.
- [Chapter 4, Functional Description, on page 55](#) contains a block diagram of the RTM and provides some information on the IPMI functionality of the RTM
- [Appendix A, Related Documentation, on page 63](#) lists further Artesyn user manuals that are related to the RTM and the ATCA-F120.

Abbreviations

This document uses the following abbreviations:

Abbreviation	Description
AMC	Advanced Mezzanine Module
ECC	Embedded Communications Computing
EMC	Electromagnetic Compatibility
EMV	Elektromagnetische Verträglichkeit
ETSI	European Telecommunications Standards Institute
IEC	International Engineering Consortium
IEEE	Institute of Electrical and Electronics Engineers
IPMI	Intelligent Platform Management Interface
IPMC	Intelligent Peripheral Management Controller
MMC	Mezzanine Management Controller
NEBS	Network Equipment-Building System
PCB	Printed Circuit Board
PICMG	PCI Industrial Computer Manufacturers Group

Abbreviation	Description
RTM	Rear Transition Module
RoHS	Restriction of Hazardous Substances Directive
SELV	Safety Extra Low Voltage Circuits
STP	Shielded Twisted Pair

Conventions

The following table describes the conventions used throughout this manual.

Notation	Description
0x00000000	Typical notation for hexadecimal numbers (digits are 0 through F), for example used for addresses and offsets
0b0000	Same for binary numbers (digits are 0 and 1)
bold	Used to emphasize a word
Screen	Used for on-screen output and code related elements or commands in body text
Courier + Bold	Used to characterize user input and to separate it from system output
<i>Reference</i>	Used for references and for table and figure descriptions
File > Exit	Notation for selecting a submenu
<text>	Notation for variables and keys
[text]	Notation for software buttons to click on the screen and parameter description
...	Repeated item for example node 1, node 2, ..., node 12
.	Omission of information from example/command that is not necessary at the time being
..	Ranges, for example: 0..4 means one of the integers 0,1,2,3, and 4 (used in registers)

This section provides warnings that precede potentially dangerous procedures throughout this manual. Instructions contained in the warnings must be followed during all phases of operation, service, and repair of this equipment. You should also employ all other safety precautions necessary for the operation of the equipment in your operating environment. Failure to comply with these precautions or with specific warnings elsewhere in this manual could result in personal injury or damage to the equipment.

Artesyn intends to provide all necessary information to install and handle the product in this manual. Because of the complexity of this product and its various uses, we do not guarantee that the given information is complete. If you need additional information, ask your Artesyn representative.

The product has been designed to meet the standard industrial safety requirements. It must not be used except in its specific area of office telecommunication industry and industrial control.

Only personnel trained by Artesyn or persons qualified in electronics or electrical engineering are authorized to install, remove or maintain the product.

The information given in this manual is meant to complete the knowledge of a specialist and must not be used as replacement for qualified personnel.

Keep away from live circuits inside the equipment. Operating personnel must not remove equipment covers. Only Factory Authorized Service Personnel or other qualified service personnel may remove equipment covers for internal subassembly or component replacement or any internal adjustment.

Do not install substitute parts or perform any unauthorized modification of the equipment or the warranty may be voided. Contact your local Artesyn representative for service and repair to make sure that all safety features are maintained.

Electrical Interference

This equipment has been tested and found to comply with the limits for a Class A digital device, pursuant to Part 15 of the FCC Rules. These limits are designed to provide reasonable protection against harmful interference when the equipment is operated in a commercial environment. This equipment generates, uses, and can radiate radio frequency energy and, if not installed and used in accordance with the instruction manual, may cause harmful interference to radio communications.

Operation of this equipment in a residential area is likely to cause harmful interference in which case the user will be required to correct the interference at his own expense. Changes or modifications not expressly approved by Artesyn could void the user's authority to operate the equipment. Board products are tested in a representative system to show compliance with the above mentioned requirements. A proper installation in a compliant system will maintain the required performance. Use only shielded cables when connecting peripherals to assure that appropriate radio frequency emissions compliance is maintained.

Operation

Damage of the RTM

High humidity and condensation on the RTM surface causes short circuits.

Do not operate the RTM outside the specified environmental limits. Make sure the RTM is completely dry and there is no moisture on any surface before applying power.

Do not operate the RTM below -5°C.

Installation

Damage of the RTM and Additional Devices and Modules

Incorrect installation or removal of additional devices or modules may damage the RTM or the additional devices or modules.

Before installing or removing additional devices or modules, read the respective documentation.

Damage of Circuits

Electrostatic discharge and incorrect installation and removal of the RTM can damage circuits or shorten their life.

Before touching the RTM or electronic components, make sure that you are working in an ESD-safe environment.

Damage of the RTM

Incorrect installation of the RTM can cause damage of the RTM.

Only use handles when installing/removing the RTM to avoid damage/deformation to the face plate and/or PCB.

Damage to RTM/Backplane or System Components

Bent pins or loose components can cause damage to the RTM, the backplane, or other system components.

Therefore, carefully inspect the RTM and the backplane for both pin and component integrity before installation.

Artesyn and our suppliers take significant steps to ensure there are no bent pins on the backplane or connector damage to the blades/RTMs prior to leaving the factory. Bent pins caused by improper installation or by inserting blades with damaged connectors could void the ECC warranty for the backplane or blades.

System Damage

Warning: The intra-building port (s) of the equipment or subassembly is suitable for connection to intra-building or unexposed wiring or cabling only. The intra-building port (s) of the equipment or subassembly **MUST NOT** be metallically connected to interfaces that connect to the outside plant (OSP) or its wiring. These interfaces are designed for use as intra-building interfaces only (Type 2 or Type 4 ports as described in GR-1089) and require isolation from the exposed OSP cabling. The addition of primary protectors is not sufficient protection in order to connect these interfaces metallically to OSP wiring.

The intra-building port(s) of the equipment or subassembly must use shielded intra-building cabling/wiring that is grounded at both ends.

SFP/SFP+ Modules

Personal Injury and Damage of the RTM and SFP/SFP+ Modules

Installing and using SFP/SFP+ modules which are not fully certified and which do not meet all relevant safety standards may damage the RTM and the SFP/SFP+ modules and may lead to personal injury.

Only use and install SFP/SFP+ modules which are fully certified and which meet all relevant safety standards.

Personal Injury

Optical SFP/SFP+ modules may be classified as laser products. When installing and using any of these SFP/SFP+ modules, the regulations which correspond to the respective laser class apply to the whole RTM. Not complying to these regulations, may lead to personal injury.

When installing and using optical SFP/SFP+ modules which are classified as laser products, make sure to comply to the respective regulations.

Eye Damage

Optical SFP/SFP+ modules may emit laser radiation when no cable is connected.

Avoid staring into open apertures to avoid damage to your eyes.

SFP/SFP+ Module Damage

The optical port plug protects the sensitive optical fibres against dirt and damage. Dirt and damage can render the SFP/SFP+ module inoperable.

Only remove the optical plug when you are ready to connect a cable to the SFP/SFP+ module. When no cable is connected, cover the port with an optical port plug.

Environment

Always dispose of used blades, system components and RTMs according to your country's legislation and manufacturer's instructions.

Dieses Kapitel enthält Hinweise, die potentiell gefährlichen Prozeduren innerhalb dieses Handbuchs vorrangestellt sind. Beachten Sie unbedingt in allen Phasen des Betriebs, der Wartung und der Reparatur des Systems die Anweisungen, die diesen Hinweisen enthalten sind. Sie sollten außerdem alle anderen Vorsichtsmaßnahmen treffen, die für den Betrieb des Produktes innerhalb Ihrer Betriebsumgebung notwendig sind. Wenn Sie diese Vorsichtsmaßnahmen oder Sicherheitshinweise, die an anderer Stelle dieses Handbuchs enthalten sind, nicht beachten, kann das Verletzungen oder Schäden am Produkt zur Folge haben.

Artesyn Embedded Technologies ist darauf bedacht, alle notwendigen Informationen zum Einbau und zum Umgang mit dem Produkt in diesem Handbuch bereit zu stellen. Da es sich jedoch um ein komplexes Produkt mit vielfältigen Einsatzmöglichkeiten handelt, können wir die Vollständigkeit der im Handbuch enthaltenen Informationen nicht garantieren. Falls Sie weitere Informationen benötigen sollten, wenden Sie sich bitte an die für Sie zuständige Geschäftsstelle von Artesyn Embedded Technologies.

Das System erfüllt die für die Industrie geforderten Sicherheitsvorschriften und darf ausschließlich für Anwendungen in der Telekommunikationsindustrie und im Zusammenhang mit Industriesteuerungen verwendet werden.

Einbau, Wartung und Betrieb dürfen nur von durch Artesyn Embedded Technologies ausgebildetem oder im Bereich Elektronik oder Elektrotechnik qualifiziertem Personal durchgeführt werden. Die in diesem Handbuch enthaltenen Informationen dienen ausschließlich dazu, das Wissen von Fachpersonal zu ergänzen, können dieses jedoch nicht ersetzen.

Halten Sie sich von stromführenden Leitungen innerhalb des Produktes fern. Entfernen Sie auf keinen Fall Abdeckungen am Produkt. Nur werksseitig zugelassenes Wartungspersonal oder anderweitig qualifiziertes Wartungspersonal darf Abdeckungen entfernen, um Komponenten zu ersetzen oder andere Anpassungen vorzunehmen.

Installieren Sie keine Ersatzteile oder führen Sie keine unerlaubten Veränderungen am Produkt durch, sonst verfällt die Garantie. Wenden Sie sich für Wartung oder Reparatur bitte an die für Sie zuständige Geschäftsstelle von Artesyn Embedded Technologies. So stellen Sie sicher, dass alle sicherheitsrelevanten Aspekte beachtet werden.

EMV

Das Produkt wurde in einem Artesyn Standardsystem getestet. Es erfüllt die für digitale Geräte der Klasse A gültigen Grenzwerte in einem solchen System gemäß den FCC-Richtlinien Abschnitt 15 bzw. EN 55022 Klasse A. Diese Grenzwerte sollen einen angemessenen Schutz vor Störstrahlung beim Betrieb des Produktes in Gewerbe- sowie Industriegebieten gewährleisten.

Das Produkt arbeitet im Hochfrequenzbereich und erzeugt Störstrahlung. Bei unsachgemäßem Einbau und anderem als in diesem Handbuch beschriebenen Betrieb können Störungen im Hochfrequenzbereich auftreten.

Warnung! Dies ist eine Einrichtung der Klasse A. Diese Einrichtung kann im Wohnbereich Funkstörungen verursachen. In diesem Fall kann vom Betreiber verlangt werden, angemessene Maßnahmen durchzuführen.

Operation

Beschädigung des RTMs

Hohe Luftfeuchtigkeit und Kondensat auf der Oberfläche des RTMs können zu Kurzschlüssen führen.

Betreiben Sie das RTM nur innerhalb der angegebenen Grenzwerte für die relative Luftfeuchtigkeit und Temperatur. Stellen Sie vor dem Einschalten des Stroms sicher, dass sich auf dem Produkt kein Kondensat befindet und betreiben Sie das RTM nicht unter -5°C.

Installation

Beschädigung des RTMs und von Zusatzmodulen

Fehlerhafte Installation von Zusatzmodulen, kann zur Beschädigung des RTMs und der Zusatzmodule führen.

Lesen Sie daher vor der Installation von Zusatzmodulen die zugehörige Dokumentation.

Beschädigung von Schaltkreisen

Elektrostatistische Entladung und unsachgemäßer Ein- und Ausbau von Blades/RTMs kann Schaltkreise beschädigen oder ihre Lebensdauer verkürzen.

Bevor Sie Blades/RTMs oder elektronische Komponenten berühren, vergewissern Sie sich, daß Sie in einem ESD-geschützten Bereich arbeiten.

Beschädigung des RTMs

Fehlerhafte Installation des RTMs kann zu einer Beschädigung des RTMs führen.

Verwenden Sie die Handles, um das RTM zu installieren/deinstallieren. Auf diese Weise vermeiden Sie, dass das Face Plate oder die Platine deformiert oder zerstört wird.

Beschädigung des RTMs, der Backplane oder von System Komponenten

Verbogene Pins oder lose Komponenten können zu einer Beschädigung des RTMs, der Backplane oder von Systemkomponenten führen.

Überprüfen Sie daher das RTM sowie die Backplane vor der Installation sorgfältig und stellen Sie sicher, dass sich beide in einwandfreien Zustand befinden und keine Pins verbogen sind.

Artesyn und unsere Zulieferer unternehmen größte Anstrengungen um sicherzustellen, dass sich Pins und Stecker von Blades/RTMs vor dem Verlassung der Produktionsstätte in einwandfreiem Zustand befinden. Verbogene Pins, verursacht durch fehlerhafte Installation oder durch Installation von Blades/RTMs mit beschädigten Steckern kann die durch ECC gewährte Garantie für Blades und Backplanes erlöschen lassen.

Beschädigung des Systems

Warnung: Die intra-Gebäude Port (s) des Geräts oder Baugruppe ist für den Anschluss an den inner Gebäude oder unbelichteten Verdrahtung oder Verkabelung nur. Die intra-Gebäude Port (s) des Geräts oder Baugruppe muss nicht metallisch mit Schnittstellen, die an der Außenanlage (OSP) oder dessen Verkabelung anschließen angeschlossen werden. Diese Schnittstellen sind für die Verwendung als intra Gebäude Schnittstellen nur entworfen, (Typ 2 oder Typ 4 Ports wie in GR-1089 beschrieben) und erfordern Isolierung von der freiliegenden OSP-Verkabelung. Die Zugabe von primären Schutz nicht ausreichenden Schutz, um diese Schnittstellen metallisch mit OSP Verdrahtung verbinden.

Die intra-Gebäude Port (s) des Gerätes oder einer Unterbaugruppe müssen abgeschirmte innerGebäudeVerkabelung / Verdrahtung, die an beiden Enden geerdet ist zu verwenden.

SFP/SFP+ Modules

Gefahr von Verletzungen sowie von Beschädigung des RTMs und SFP/SFP+-Modulen
Die Installation und der Betrieb von SFP/SFP+-Modulen, welche nicht zertifiziert sind und welche nicht den Sicherheitsstandards entsprechen, kann Verletzungen zur Folge haben sowie zur Beschädigung des RTMs und von SFP/SFP+-Modulen führen.
Verwenden Sie daher nur SFP/SFP+-Module, die zertifiziert sind und die den Sicherheitsstandards entsprechen.

Verletzungsgefahr

Optische SFP/SFP+-Module können als Laserprodukte klassifiziert sein. Wenn Sie solche SFP/SFP+-Module installieren und betreiben, so gelten die entsprechenden Bestimmungen für Laserprodukte für das gesamte RTM. Werden diese Bestimmungen nicht eingehalten, so können körperliche Verletzungen die Folge sein.

Wenn Sie SFP/SFP+-Module betreiben, welche als Laserprodukte klassifiziert sind, so stellen Sie sicher, dass die entsprechenden Bestimmungen für Laserprodukte eingehalten werden.

Verletzungsgefahr der Augen

Optische SFP/SFP+-Module können Laserstrahlen aussenden, wenn kein Kabel angeschlossen ist.

Vermeiden Sie es daher, direkt in die Öffnung eines SFP/SFP+-Moduls zu sehen, um Verletzungen der Augen zu vermeiden.

Beschädigung von SFP/SFP+-Modulen

Die Schutzkappe eines SFP/SFP+-Modules dient dazu, die sensible Optik des SFP/SFP+-Modules gegen Staub und Schmutz zu schützen.

Entfernen Sie die Schutzkappe nur dann, wenn Sie beabsichtigen, ein Kabel anzuschliessen. Andernfalls belassen Sie die Schutzkappe auf dem SFP/SFP+-Modul.

Umweltschutz

Entsorgen Sie alte Batterien und/oder Blades/Systemkomponenten/RTMs stets gemäß der in Ihrem Land gültigen Gesetzgebung, wenn möglich immer umweltfreundlich.

1.1 Features

The RTM-ATCA-F120-OPT is a rear transition module (RTM) as defined in the PICMG 3.0 revision 2.0 AdvancedTCA Base Specification for AdvancedTCA systems. It is designed to be used with the ATCA-F120 base blade and provides the following I/O interfaces towards the back of the ATCA-F120:

- Four 10 Gigabit Ethernet Fabric Channel uplinks via SFP+ connectors
- Two 10 Gigabit Ethernet Base Channel uplinks via SFP+ connectors
- Four 1 Gigabit Ethernet Base Channel interfaces via SFP connectors
- Two 1 Gigabit Ethernet Fabric Channel interfaces via SFP connectors
- Two RJ-45 telecom clocking interface connectors for inter-shelf clocking configurations
- One serial RS-232 interface for accessing the base blade
- On-board mezzanine management controller (MMC) compliant to IPMI 2.0

Figure 1-1 Overview

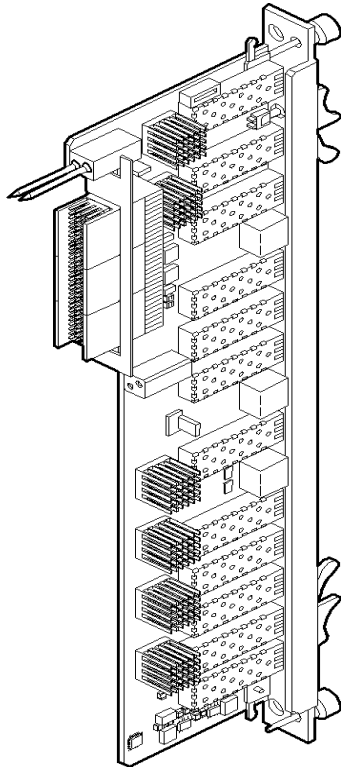

1.2 Mechanical Data

The following table lists physical dimensions and weight of the RTM.

Table 1-1 Mechanical Data

Feature	Value
Physical dimension of PCB	322.25 mm x 70 mm
Weight of RTM	0.7 kG

1.3 Ordering Information

Consult your local Artesyn sales representative for available RTM variants and their order numbers.

Hardware Preparation and Installation

2.1 Overview

This chapter describes all necessary steps you need to take in order to install the RTM-ATCA-F120-OPT. The main steps are:

- Inspect the shipment and unpack the RTM
- Make sure environmental and power requirements are met
- Install the RTM

2.2 Unpacking and Inspecting the RTM

NOTICE

Damage of Circuits

Electrostatic discharge and incorrect installation and removal of the blade can damage circuits or shorten their life.

Before touching the blade or electronic components, make sure that you are working in an ESD-safe environment.

To inspect the shipment, perform the following steps.

Shipment Inspection

1. Verify that you have received all items of your shipment:
 - Printed user manual (Getting Started guide)
 - RTM-ATCA-F120-OPT

Any optional items ordered

2. Check for damage and report any damage or differences to the customer service.



- The RTM is thoroughly inspected before shipment. If any damage occurred during transportation or any items are missing, please contact our customer's service immediately.
- Remove the desiccant bag shipped together with the blade and dispose of it according to your country's legislation.

2.3 Environmental and Power Requirements

The following environmental and power requirements are applicable to the board.

2.3.1 Environmental Requirements

You must make sure that the blade, when operated in your particular system configuration, meets the environmental requirements specified below.



Operating temperatures refer to the temperature of the air circulating around the RTM, and not to component temperatures.

If you integrate the RTM in your own, non-Artсын, system, please contact your local sales representative for further safety information.

NOTICE

RTM Damage

High humidity and condensation on the RTM surface causes short circuits.

Do not operate the RTM outside the specified environmental limits. Make sure the RTM is completely dry and there is no moisture on any surface before applying power.

Do not operate the RTM below 0°C.

Table 2-1 Environmental Requirements

Requirement	Operating	Non-Operating
Temperature	0°C to +40°C (normal operation) according to NEBS Standard GR-63-CORE 0°C to +55°C (exceptional operation) according to NEBS Standard GR-63-CORE	-40°C to +85°C
Temp. Change	+/- 0.25°C/min according to NEBS Standard GR-63-CORE	+/- 0.25°C/min
Rel. Humidity	5% to 95% non-condensing according to Artesyn-internal environmental requirements	5% to 95% non-condensing according to Artesyn-internal environmental requirements
Vibration	0.1g from 5 to 100 Hz and back to 5 Hz at a rate of 0.1 octave/minute	5-20 Hz @ 0.01 g ² /Hz 20-200 Hz @ -3.0 dB/octave Random 5-20 Hz @ 1 m ² /Sec ³ Random 20-200 Hz @ -3 m/Sec ²
Shock	Half-sine, 11 m/Sec, 30mSec/sec ²	Blade level packaging Half-sine, 6 mSec at 180 m/Sec ²
Free Fall		1,200 mm/all edges and corners 1.0m (Packaged) per ETSI 300 019-2-2 (Blade level packaging) 100mm (unpacked) per GR-63-CORE

2.3.2 Power Requirements

The RTM has a typical power dissipation of 22W, and a maximum power dissipation of 30W.

2.4 Installing and Removing the RTM

The RTM can be installed into a powered or non-powered system.

NOTICE

RTM Damage

Installing the RTM with other blades than the ATCA-F120 may damage the RTM and the front blade.

Only install the RTM with the Artesyn ATCA-F120 blade.

Damage of Circuits

Electrostatic discharge and incorrect RTM installation and removal can damage circuits or shorten their life.

Before touching the RTM or electronic components, make sure that you are working in an ESD-safe environment.

2.4.1 Installing the RTM

You can install the RTM into a system if the front blade is already installed or if it is not installed. If the front blade is already installed, its payload has to be powered down first.

Installation Procedure with Installed Front Blade

The following procedure describes the installation of the RTM. It assumes that your system is powered. If your system is unpowered, you can disregard the blue LED and thus skip the respective step. In this case it is a purely mechanical installation.

1. Locate the slot the RTM is to be installed into the shelf's rear which must be the same as that of the front blade.
2. Open the lower handle of the front blade in order to power down its payload. The blue LED on the front blade starts to flash. This indicates that the front blade is informing the shelf manager about its desire to power down its payload.
3. Wait until the blue LED on the front blade is ON. This indicates that the front blade's payload is powered down.

4. Ensure that the top and the bottom handles of the RTM are in an outward position by squeezing the lever and the latch together.

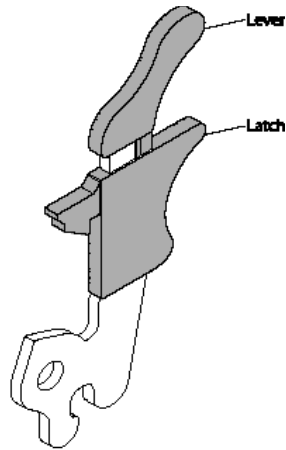

5. Insert the RTM into the shelf by placing the top and bottom edges in the card guides of the slot.
6. Slide the RTM into the slot.
7. Apply equal and steady pressure to the RTM to carefully slide the RTM into the shelf until you feel resistance. Continue to gently push the RTM until the RTM connectors engage.
8. Squeeze the lever and the latch together and hook the lower and the upper handle into the shelf rail recesses.

9. Fully insert the RTM and lock it to the shelf by pressing the two components of the lower and the upper handles together and turning the handles toward the face plate.

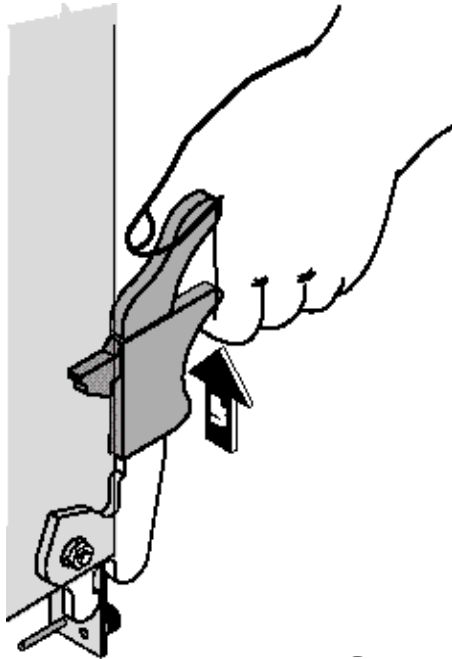

If your shelf is powered, as soon as the RTM is connected to the front blade, the blue LED is illuminated, and will remain illuminated until both the lower handle of the RTM and the lower handle of the front blade are closed.

10. Close the lower handle of the front blade in order to power up the payload of both the front blade and the RTM.
The blue LEDs of both the front blade and the RTM start to flash. This indicates that the front blade is informing the shelf manager about its desire to power up the payload of both the front blade and the RTM.
11. Tighten both face plate screws on the RTM.
12. Wait until the blue LEDs of both the front blade and the RTM are OFF.

A switched OFF blue LED indicates that the payload of the respective blade or RTM has been powered up and is active.

13. Plug interface cable into face plate connectors, if applicable.

Installation Procedure without Installed Front Blade

The following procedure describes the installation of the RTM.

1. Locate the slot the RTM is to be installed into the shelf's rear which must be the same as that of the front blade.
2. Ensure that the top and the bottom handles of the RTM are in an outward position by squeezing the lever and the latch together.

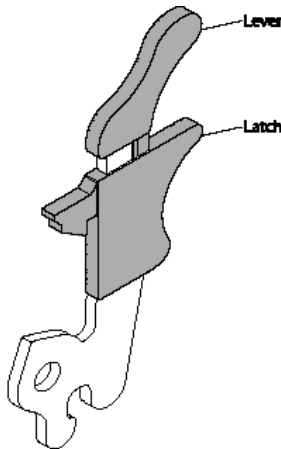

3. Insert the RTM into the shelf by placing the top and bottom edges in the card guides of the slot.
4. Slide the RTM into the slot.
5. Apply equal and steady pressure to the RTM to carefully slide the RTM into the shelf until you feel resistance. Continue to gently push the RTM until the RTM connectors engage.

6. Squeeze the lever and the latch together and hook the lower and the upper handle into the shelf rail recesses.
7. Fully insert the RTM and lock it to the shelf by pressing the two components of the lower and the upper handles together and turning the handles toward the face plate.

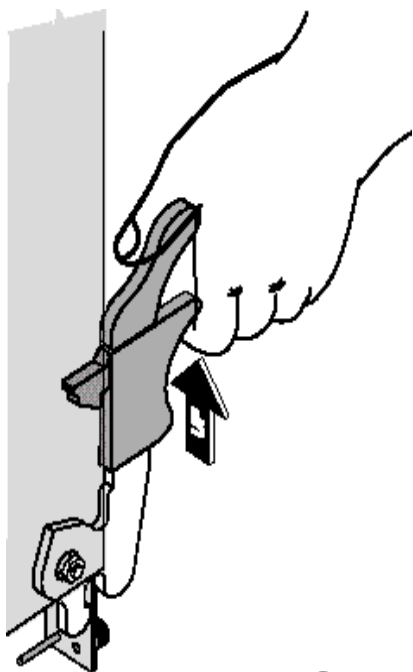

8. Tighten both face plate screws on the RTM.
9. Insert the front blade from the system's front into the same slot as the RTM. For a detailed instruction of the installation procedure for the front blade please refer to *ATCA-F120 Installation and Use*.
As soon as the front blade is connected to the backplane, the blue hot swap LEDs of both the front blade and the RTM are illuminated permanently. This indicates that the IPMC of the front blade and the MMC of the RTM are powered up.
10. Close the handles of the front blade.

The blue LEDs on both the front blade and the RTM start flashing. This indicates that the front blade is informing the shelf manager about its desire to power up the payload of both the front blade and the RTM.

11. Tighten the two face plate screws on the front blade.
12. Wait until the blue LEDs on both the front blade and the RTM are OFF.
Switched off blue LEDs indicate that the payload of the respective blade or RTM has become active.
13. Plug interface cable into face plate connectors, if applicable.

2.4.2 Removing the RTM

Removal Procedure

The following procedure describes the removal of the RTM. It assumes that your system is powered. If your system is unpowered, you can disregard the blue LED and thus skip the respective step. In this case it is a purely mechanical procedure.

NOTICE

Damage of RTM and Front Blade

Removing the RTM from the system while the payload of the front blade is powered up may damage the front blade and RTM.

Whenever removing the RTM from the system, you have to power down the payload of the front blade first.

1. Unlatch the lower handle outward by squeezing the lever and the latch together and turning the handle outward only enough to unlatch the handle from the face plate, that means until you feel a resistance. Do not rotate the handle fully outwards.

The blue LED blinks indicating that the shelf manager is informed about the desire of the blade to power down the payload of both the front blade and the RTM and the power-down process is ongoing.

NOTICE

Data Loss

Removing the RTM with the system power on and the blue LED on the front blade still flashing causes data loss.

Before removing the RTM from a powered system, power down the slot by opening the lower handle of the front blade and wait until the blue LED is permanently ON.

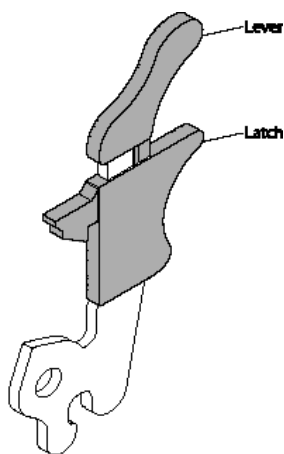

2. Wait until the blue LEDs on both the front blade and the RTM are permanently ON. A permanently switched ON LED indicates that the payload of respective blade or RTM has been powered down.

3. Unlatch the upper handle and rotate both handles fully outward.
4. Remove interface cables from face plate connectors, if applicable.
5. Loosen the two RTM face plate screws.
6. Remove the RTM from the slot.

2.5 Installing and Removing SFP/ SFP+ Modules

This section describes how to install and remove SFP and SFP+ modules. For details about supported SFP/SFP+ modules refer to [Interface Connectors on page 43](#).

	CAUTION
	<p>Eye Damage Optical SFP/SFP+ modules may emit laser radiation when no cable is connected. Avoid staring into open apertures to avoid damage to your eyes.</p> <p>Personal Injury and Damage of the RTM and SFP/SFP+ Modules Installing and using SFP/SFP+ modules which are not fully certified and which do not meet all relevant safety standards may damage the RTM and the SFP/SFP+ modules and may lead to personal injury. Only use and install SFP/SFP+ modules which are fully certified and which meet all relevant safety standards.</p> <p>Personal Injury Optical SFP/SFP+ modules may be classified as laser products. When installing and using any of these SFP/SFP+ modules, the regulations which correspond to the respective laser class apply to the whole RTM. Not complying to these regulations, may lead to personal injury. When installing and using optical SFP/SFP+ modules which are classified as laser products, make sure to comply to the respective regulations.</p>



SFP/SFP+ modules can be installed/removed both while the RTM is powered and non-powered. The presence and also the type of SFP/SFP+ modules is automatically detected.

The maximum power consumption of all installed SFP/SFP+ modules must not exceed 12W.

2.5.1 Installing an SFP/SFP+ Module

Procedure

In order to install an SFP/SFP+ module, proceed as follows:

1. Slide the SFP/SFP+ module into the slot until it locks into position.

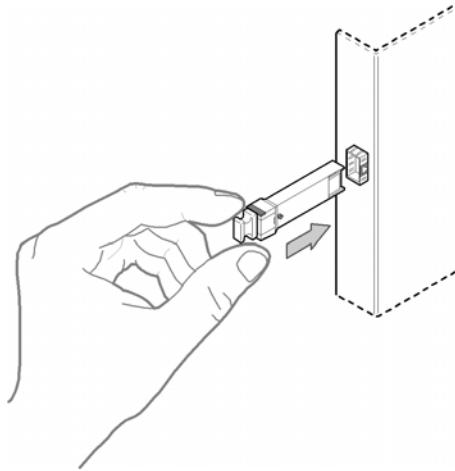

2. Remove the optical port plug.

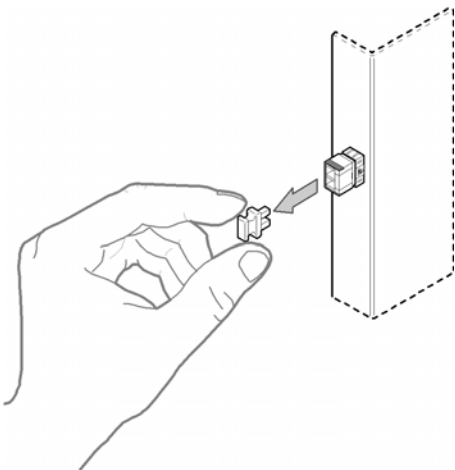

NOTICE

SFP/SFP+ Module Damage

The optical port plug protects the sensitive optical fibres against dirt and damage. Dirt and damage can render the SFP/SFP+ module inoperable.

Only remove the optical plug when you are ready to connect a cable to the SFP/SFP+ module. When no cable is connected, cover the port with an optical port plug.

3. Connect the network cable to the SFP/SFP+ module

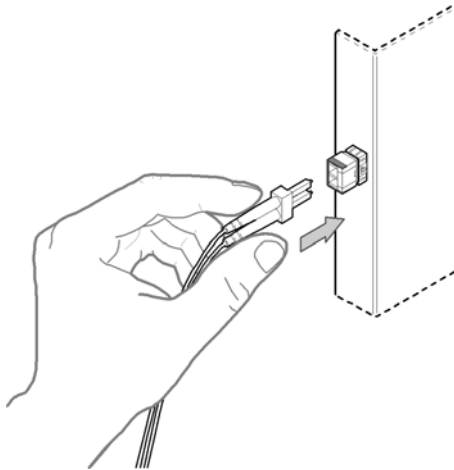

2.5.2 Removing an SFP/SFP+ Module

Procedure

In order to remove an SFP/SFP+ module, proceed as follows.

1. Remove any connected cable from the SFP module.

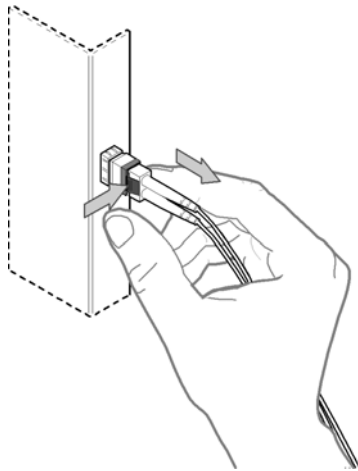

2. Open the SFP/SFP+ latch. Note that the latch mechanism of your SFP/SFP+ module may be slightly different compared to the latch shown in the following figure.

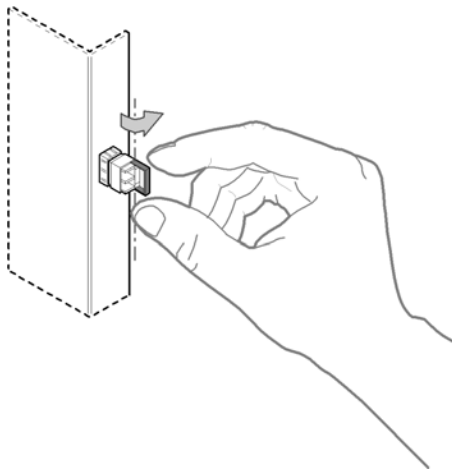

3. Grasp the SFP/SFP+ module and carefully slide it out of the slot.

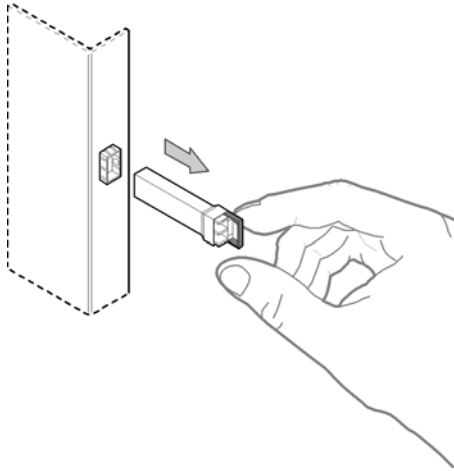

4. Cover the optical port with the optical port plug.

NOTICE

SFP/SFP+ Module Damage

The optical port plug protects the sensitive optical fibres against dirt and damage. Dirt and damage can render the SFP/SFP+ module inoperable.

Only remove the optical plug when you are ready to connect a cable to the SFP/SFP+ module. When no cable is connected, cover the port with an optical port plug.

3.1 Overview

This chapter describes:

- Face plate LEDs
- Face plate Interface connectors
- Rear panel connectors

3.2 LEDs and Interface Connectors

The following figure shows the face plate of the RTM.

Figure 3-1 Face Plate

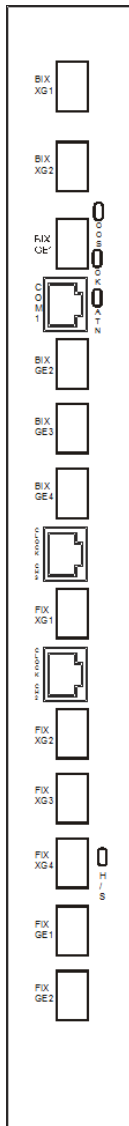

3.2.1 LEDs

The RTM provides four LEDs at its face plate. Their meaning is described in the following table.

Table 3-1 Face Plate LEDs

LED	Description
OOS	Out-Of-Service This LED is controlled by upper-layer software, such as middleware or applications. It works in parallel to the OOS LED at the face plate of the front blade. An example of middleware that may use this LED is Avantellis HA software which runs on Centellis hardware.
OK	RTM Power Status Green: The RTM power has been enabled by the MMC. OFF: RTM power is disabled.
ATN	This LED is controlled by upper layer software, such as middleware or applications. It works in parallel to the ATTN LED at the front blade's face plate. An example of middleware that may use this LED is Avantellis HA software which runs on Centellis hardware.
H/S	Indicates whether the RTM can be installed or removed. During RTM installation: Permanently blue: RTM powers up. OFF: RTM is active. During RTM removal: Flashing blue: RTM notifies shelf management controller of desired deactivation. In this state the RTM must not be removed. Permanently blue: RTM is powered down and is ready to be extracted. OFF: RTM is active and cannot be removed.

3.2.2 Interface Connectors

The RTM provides access to the following interfaces at its face plate.

- Six Fabric Channel interface uplinks
- Six Base channel interface uplinks

- Two RJ-45 telecom clocking interfaces for inter-shelf clocking configurations
- Serial interface for accessing the main blade's CPU

3.2.2.1 Fabric Channel Uplinks

The RTM provides access to the following six Ethernet fabric channel uplink interfaces at its face plate:

- Four 10 Gigabit Ethernet uplink interfaces via SFP+ connectors
- Two 1 Gigabit Ethernet interfaces via SFP connectors

Their location is shown in the following figure.

Figure 3-2 Location of Ethernet Fabric Channel Uplink Interfaces

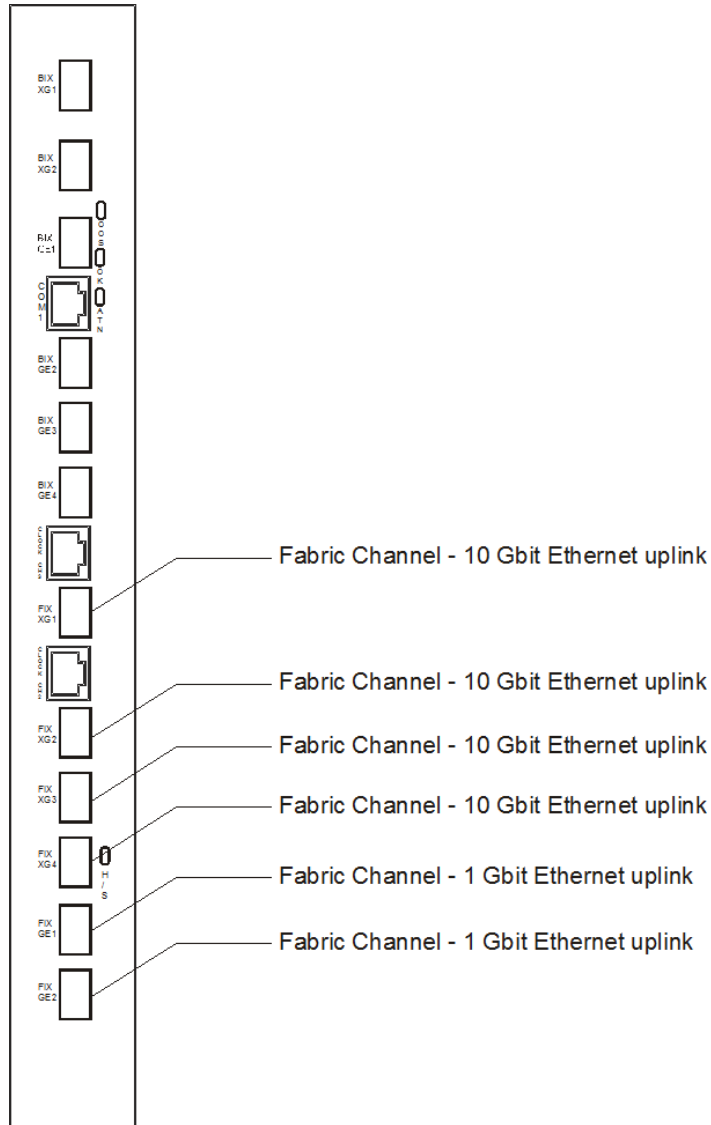

3.2.2.1.1 10 GBit Fabric Interface Channel Uplinks

The four cages for the 10 GBit uplinks can be equipped with standard optical SFP+ connectors and support Ethernet connections in compliance with the IEEE 802.3ak standard. Alternatively, you may populate the SFP+ connectors with SFP connectors for copper and optical Ethernet connections. In this case, only 1 GBit connections are supported.

During the qualification testing of the RTM, the following SFP+ models were used:

- 10Gb/s 850nm Multimode Datacom SFP+ Transceiver (FTLX8571D3BCL). Orderable via Artesyn P/N: 5806802A01
- RoHS-6 Compliant 10Gb/s 10km Single Mode Datacom SFP+ Transceiver (FTLX1471D3BCL). Orderable via Artesyn P/N: 5806803A01

These modules passed all tests successfully without incidents. They are also listed in the Artesyn Embedded Technologies sales configurator. When using SFP+ modules, we recommend to use these models.

The SFP/SFP+ modules can be installed/removed both while the RTM is powered and non-powered. The presence and also the type of SFP/SFP+ modules is automatically detected.

When using 1 GBit copper SFP modules, the speed is determined through auto-negotiation per the 802.11 Ethernet specification. Optical modules do not support auto-negotiation. The SFP cable should be appropriately matched to the SFP module type per the manufacturer's recommendations.

The following table shows which switch MIB OID each cage corresponds to.

Table 3-2 Fabric Channel 10 GBit Uplink Connectors - Port - MIB OID Assignment

Face Plate Label	MIB OID	Ethernet Type
FIX XG1	<shelf>.<slot>.2.17	10 GBit
FIX XG2	<shelf>.<slot>.2.16	10 GBit
FIX XG3	<shelf>.<slot>.2.19	10 GBit
FIX XG4	<shelf>.<slot>.2.18	10 GBit

3.2.2.1.2 1 GBit Fabric Interface Uplinks

The two cages for 1 GBit connections can be equipped with standard SFP connectors for copper and optical connections.

The SFP modules can be installed/removed both while the RTM is powered and non-powered. The presence and also the type of SFP modules is automatically detected.

When using copper SFP modules, the speed is determined through auto-negotiation per the 802.11 Ethernet specification. Optical modules do not support auto-negotiation.

The following table shows which switch MIB OID each cage corresponds to.

Table 3-3 Fabric Channel 1 GBit Uplink Connectors - Port - MIB OID Assignment

Face Plate Label	MIB OID	Ethernet Type
FIX GE1	<shelf>.<slot>.2.40	1 GBit
FIX GE2	<shelf>.<slot>.2.41	1 GBit

3.2.2.2 Base Channel Interface Connectors

The RTM provides access to the following six Ethernet base channel uplink interfaces at its face plate:

- Two 10 Gigabit Ethernet uplink interfaces via SFP+ connectors
- Four 1 Gigabit Ethernet interfaces via SFP connectors

Access to the two base channel 10 Gigabit uplinks is provided via two SFP+ cages labelled BIX-XG1 to FIX-XG2. Their location is shown in the following figure.

Figure 3-3 Location of Base Interface Uplink Interface Connectors

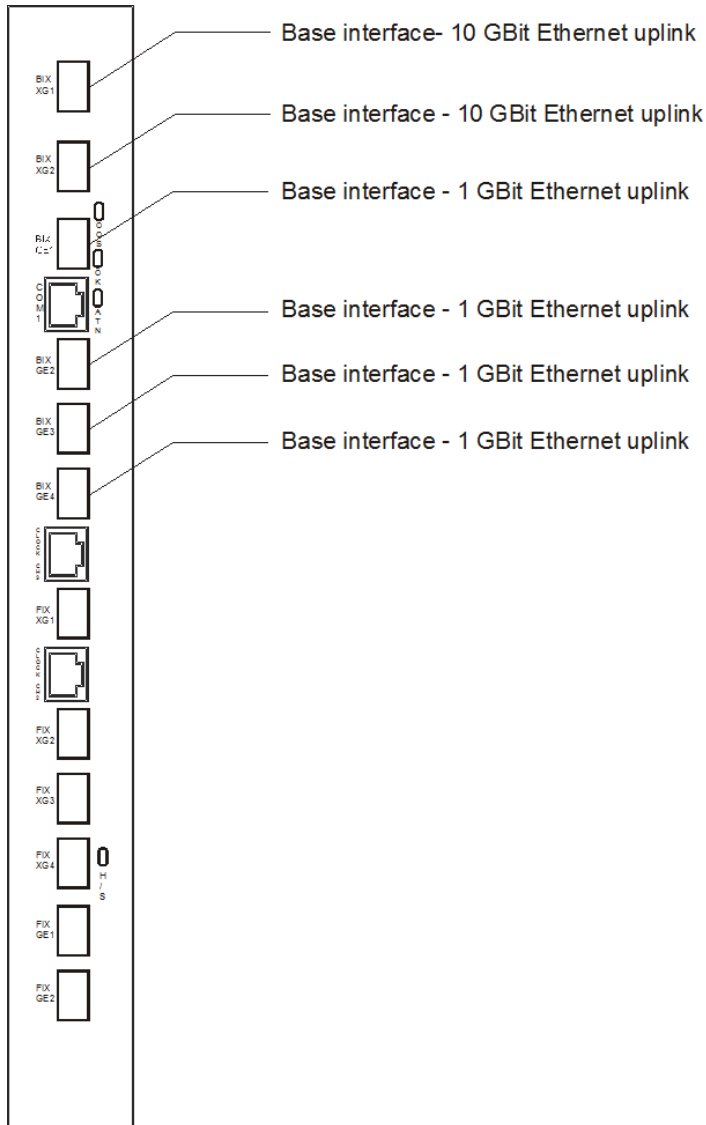

3.2.2.2.1 10 GBit Base Interface Uplinks

These cages can be equipped with standard optical SFP+ connectors for 10 Gigabit connections and support Ethernet connections in compliance with the IEEE 802.3ak standard.



The attached Ethernet switch supports only 10Gbit connections on these ports, i.e. 1 Gbit SFP modules are not supported.

During the qualification testing of the RTM, the following SFP+ models were used:

- 10Gb/s 850nm Multimode Datacom SFP+ Transceiver (FTLX8571D3BCL). Orderable via Artesyn P/N: 5806802A01
- RoHS-6 Compliant 10Gb/s 10km Single Mode Datacom SFP+ Transceiver (FTLX1471D3BCL). Orderable via Artesyn P/N: 5806803A01

These modules passed all tests successfully without incidents. They are also listed in the Artesyn Embedded Technologies sales configurator. When using SFP+ modules, we recommend to use these models.

The SFP+ modules can be installed/removed both while the RTM is powered and non-powered. The presence and also the type of SFP+ modules is automatically detected.

The following table shows which switch MIB OID each cage corresponds to.

Table 3-4 Base Channel 10 GBit Uplink Connectors - Port - MIB OID Assignment

Face Plate Label	MIB OID	Ethernet Type
BIX XG1	<shelf>.<slot>.1.25	10 GBit
BIX XG2	<shelf>.<slot>.1.26	10 GBit

3.2.2.2.2 1 GBit Base Interface Uplinks

The four cages for 1 Gbit connections can be equipped with standard SFP connectors for copper and optical connections.

The SFP modules can be installed/removed both while the RTM is powered and non-powered. The presence and also the type of SFP modules is automatically detected.

When using copper SFP modules, the speed is determined through auto-negotiation per the 802.11 Ethernet specification. Optical modules do not support auto-negotiation. A 1Gbit SFP module must be connected to 1 Gbit fibre cables.

The following table shows which switch MIB OID each cage corresponds to.

Table 3-5 Base Channel 1 GBit Uplink Connectors - Port - MIB OID Assignment

Face Plate Label	MIB OID	Ethernet Type
BIX GE1	<shelf>.<slot>.1.17	1 GBit
BIX GE2	<shelf>.<slot>.1.18	1 GBit
BIX GE3	<shelf>.<slot>.1.19	1 GBit
BIX GE4	<shelf>.<slot>.1.20	1 GBit

3.2.2.3 SFP/SFP+ Module Hot Swap

All SFP/SFP+ modules are hot-swappable. Changes in the network topology, including insertion or removal of SFP/SFP+ modules and the insertion or removal of optical cables, are monitored by the ATCA-F120 BBS kernel.

Due to safety concerns, the kernel will disable the optical transmitter on the SFP port (laser output) when a SFP/SFP+ module is removed. Conversely, the optical transmitter on the SFP port is enabled when the SFP/SFP+ module is inserted. These events are monitored and handled by the kernel; no action is required by operator.

When the kernel detects a discontinuity in the signal path that allows light to escape, e.g. a physical break in the optical fiber or an unplugged connector or when an SFP/SFP+ has been inserted, but the optical cable is missing, signals may be reduced to safer levels without losing integrity. Periodic heartbeat messages are transmitted until a connection has been established. Once established, all channels begin operating normal levels.

3.2.2.4 Telecom Clocking Connectors

The RTM provides two telecom clock extension connectors, named CH2 and CH3, at its face plate. Their location is shown in the following figure.

Figure 3-4 Location of Clock Extension Connectors

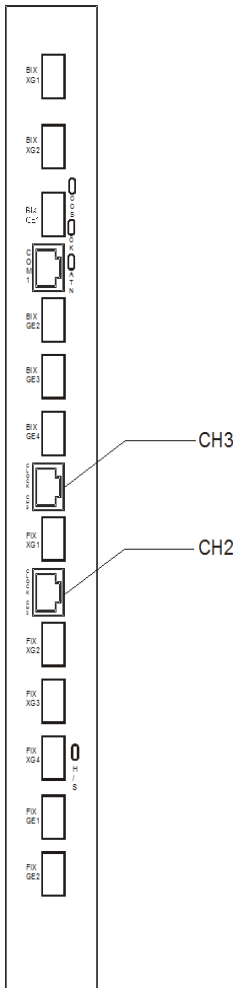

These connectors allow the RTM to distribute telecom clocking signals generated by an appropriate AMC module installed on the ATCA-F120 to two external shelves.



The telecom clocking interfaces are currently not supported. Consult your local Artesyn sales representative for further details.

3.2.2.5 Serial Interface Connector

The RTM provides a RJ-45 based serial interface connector at its face plate. It can be used to access the ATCA-F120 CPU in order to access a Linux shell for example or configure the U-Boot firmware. Note that by default this interface is disabled and the serial interface of the CPU is routed to the ATCA-F120 face plate. If you wish to route the serial interface to the RTM instead, then you need to modify the ATCA-F120 on-board configuration switch. Refer to the *ATCA-F120 Installation and Use* guide for details about how to do this.

The location and pinout of the serial interface connector at the RTM's face plate are as follows.

Figure 3-5 Location of Serial Interface Connectors

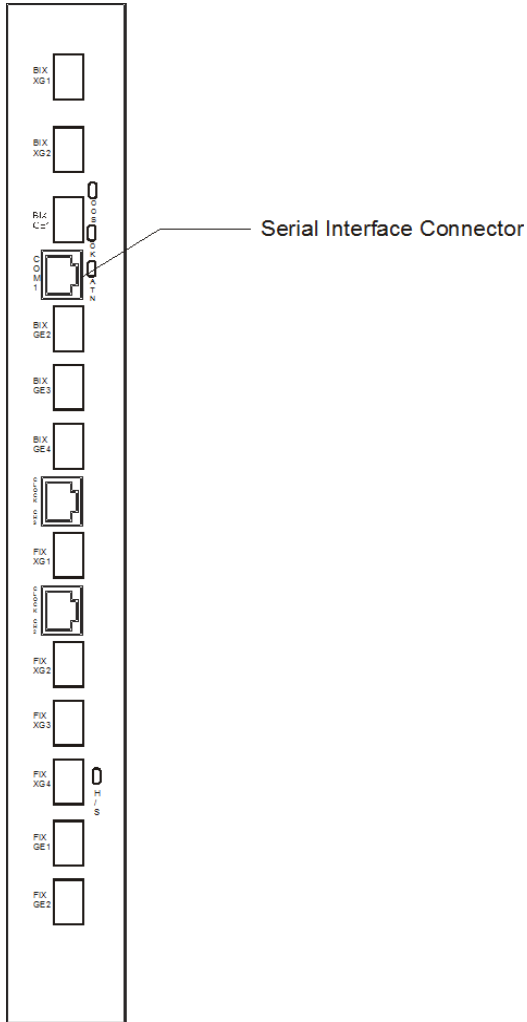

The following table describes the used pinout of the RJ-45 connector.

Table 3-6 Serial Interface - Pinout

	Pin	Signal
	1	n.c.
	2	n.c.
	3	n.c.
	4	GND
	5	RTM_RX
	6	RTM_TX
	7	n.c.
	8	n.c.

4.1 Overview

This chapter contains the following information:

- Block diagram
- Mezzanine management controller

4.2 Block Diagram

The following figure shows the main functional blocks of the RTM.

Figure 4-1 Block Diagram

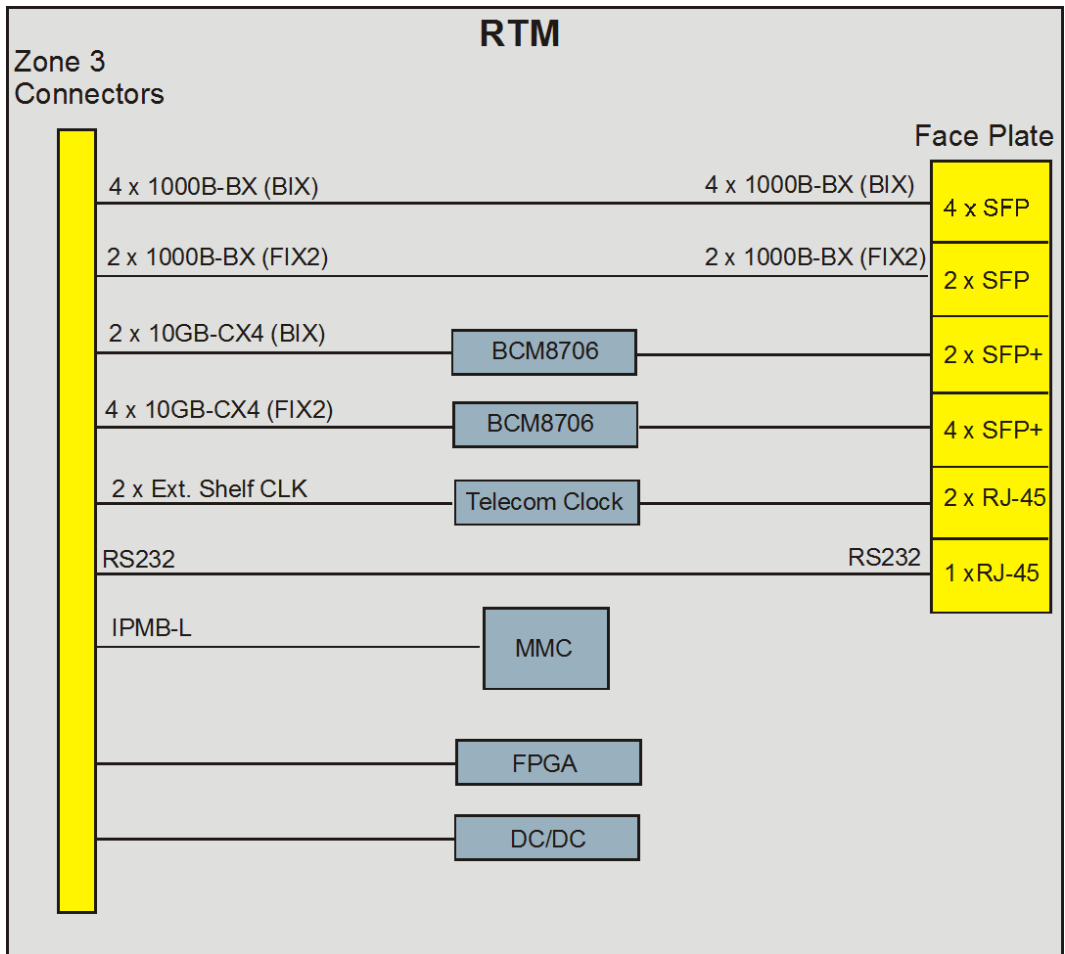

4.3 Mezzanine Management Controller

The RTM provides the a Mezzanine Management Controller (MMC) based on the Atmega128L controller which is compliant to the IPMI v1.5 standard. The MMC is connected to the front blade's IPMC via IPMB-L.

The MMC provides access to several RTM status sensors that are accessible via IPMI. These sensors are listed in the following table.

Table 4-1 IPMI Sensors Overview

Sensor Name	Sensor Type	Sensor Number
Bottom Edge Temp	Temperature	0xA2
Ejector State	Button / Switch	0x7F
LOS SFP01	Other FRU	0x20
LOS SFP02	Other FRU	0x21
LOS SFP03	Other FRU	0x22
LOS SFP04	Other FRU	0x23
LOS SFP05	Other FRU	0x24
LOS SFP06	Other FRU	0x25
LOS SFP07	Other FRU	0x26
LOS SFP08	Other FRU	0x27
LOS SFP09	Other FRU	0x28
LOS SFP10	Other FRU	0x29
LOS SFP11	Other FRU	0x2A
LOS SFP12	Other FRU	0x2B
Present SFP01	Other FRU	0x10
Present SFP02	Other FRU	0x11
Present SFP03	Other FRU	0x12
Present SFP04	Other FRU	0x13
Present SFP05	Other FRU	0x14
Present SFP06	Other FRU	0x15

Table 4-1 IPMI Sensors Overview (continued)

Sensor Name	Sensor Type	Sensor Number
Present SFP07	Other FRU	0x16
Present SFP08	Other FRU	0x17
Present SFP09	Other FRU	0x18
Present SFP10	Other FRU	0x19
Present SFP11	Other FRU	0x1A
Present SFP12	Other FRU	0x1B
RTM 1.0 V	Voltage	0x00
RTM 1.2 V	Voltage	0x04
RTM 12 V	Voltage	0x01
RTM 2.5 V	Voltage	0x03
RTM 3.3 V	Voltage	0x02
RTM-F120-OPT MMC	Artesyn IPMC Status	0xA0
RTM FPGA Vers.	Artesyn Firmware Revision	0x87
RTM Rptr Temp	Temperature	0xA3
Temp. SFP01	Temperature	0x40
Temp. SFP02	Temperature	0x41
Temp. SFP03	Temperature	0x42
Temp. SFP04	Temperature	0x43
Temp. SFP05	Temperature	0x44
Temp. SFP06	Temperature	0x45
Temp. SFP07	Temperature	0x46
Temp. SFP08	Temperature	0x47
Temp. SFP09	Temperature	0x48
Temp. SFP10	Temperature	0x49
Temp. SFP11	Temperature	0x4A
Temp. SFP12	Temperature	0x4B
Top Edge Temp	Temperature	0xA1

Table 4-1 IPMI Sensors Overview (continued)

Sensor Name	Sensor Type	Sensor Number
TX Fault SFP01	Other FRU	0x30
TX Fault SFP02	Other FRU	0x31
TX Fault SFP03	Other FRU	0x32
TX Fault SFP04	Other FRU	0x33
TX Fault SFP05	Other FRU	0x34
TX Fault SFP06	Other FRU	0x35
TX Fault SFP07	Other FRU	0x36
TX Fault SFP08	Other FRU	0x37
TX Fault SFP09	Other FRU	0x38
TX Fault SFP10	Other FRU	0x39
TX Fault SFP11	Other FRU	0x3A
TX Fault SFP12	Other FRU	0x3B

The following figure shows the location of the on-board temperature sensors.

Figure 4-2 Location of IPMI Temperature Sensors

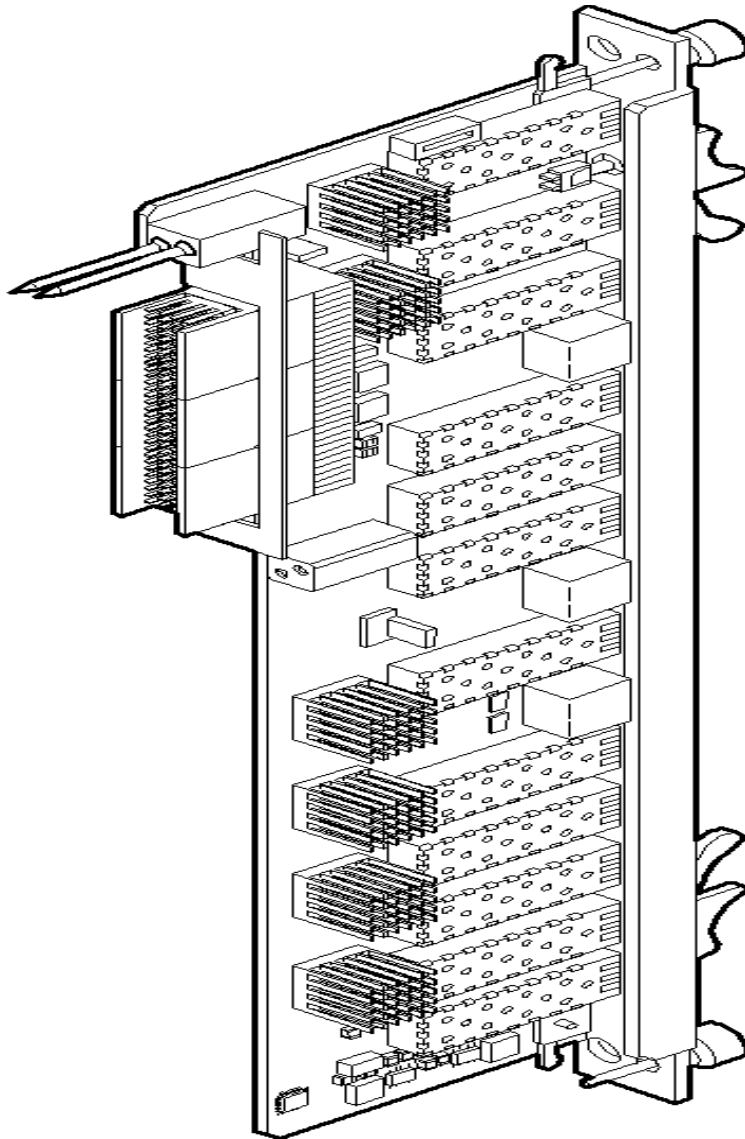

For further details about these sensors as well as further IPMI-related information, refer to the *RTM-ATCA-F120-OPT: Control via IPMI Programmer's Reference*.

Related Documentation

A.1 Artesyn Embedded Technologies - Embedded Computing Documentation

The publications listed below are referenced in this manual. You can obtain electronic copies of Artesyn Embedded Technologies - Embedded Computing publications by contacting your local Artesyn sales office. For released products, you can also visit our Web site for the latest copies of our product documentation.

1. Go to www.artesyn.com/computing.
2. Under SUPPORT, click TECHNICAL DOCUMENTATION.
3. Under FILTER OPTIONS, click the Document types drop-down list box to select the type of document you are looking for.
4. In the Search text box, type the product name and click GO.

Table A-1 Artesyn Embedded Technologies - Embedded Computing Publications

Document Title and Source	Publication Number
ATCA-F120 Installation and Use	6806800D06



Artesyn Embedded Technologies, Artesyn and the Artesyn Embedded Technologies logo are trademarks and service marks of Artesyn Embedded Technologies, Inc. All other product or service names are the property of their respective owners.

© 2016 Artesyn Embedded Technologies, Inc.