

# RTM-ATCA-STOR Quick Start Guide

P/N: 6806800V40A February 2021

## 1 Box contents

Make sure you receive all items of your shipment:

- One RTM-ATCA-STOR module
- One printed copy of Quick Start Guide (this document)
- One printed copy of Safety Notes Summary



When installing or servicing the system or accessories, strictly observe the safety precautions in the *Safety Notes Summary*. Ignoring these instructions can void the system warranty and cause personal injury or property damage.

## 2 ESD

Use ESD protection



Electrostatic discharge and incorrect installation or removal of the card can damage circuit or shorten its life.

Use a properly grounded ESD wrist strap or work in an ESD-safe environment.

Connect to the ESD connector at the front or the rear of the system.

## 3 Site preparation

Make sure that all environmental and power requirements defined in the *RTM-ATCA-STOR Installation and Use* manual are met.

Operating temperatures refer to the temperature of the air circulating around the module and not to the actual component temperature.

## 4 Install the RTM (with front blade installed)

### Notes:

- Use the following installation procedure when there is a front blade installed in the chassis. See Step 5 if no front blade is installed in the chassis.
  - The RTM-ATCA-STOR has two (2) NVMe U.2 drive carrier assemblies (DCAs) preinstalled in the module.
  - Refer to the diagrams at right for the location of the latch, handle, retention screws and latch positions.
  - The RTM-ATCA-STOR is hot-swappable and can be installed or removed from the chassis without powering down its associated front blade if supported by the front blade. Refer to the SMART EC documentation for the corresponding front blade for further details about RTM hot swap.
1. Locate the slot where the RTM is to be installed, which must be the same slot as the corresponding front blade.
  2. Slide the top latch on the RTM module to the release position; the handle automatically raises outward.
  3. Carefully insert the RTM into the slot by placing the top and bottom edges in the card guides of the slot.
  4. Slide the RTM into the slot, applying equal and steady pressure to the RTM until you feel resistance.
  5. Continue to gently push the RTM into the slot until the RTM connectors engage.
  6. Fully insert the blade and then push the handle inwards. The latch automatically locks the handle. If your chassis is powered, as soon as the RTM is connected to the front blade, the blue LED lights up and remains lit until the handle of the RTM is closed.
  7. Wait until the blue LEDs on the front blade and the RTM are unlit. The blue LED when it is unlit indicates that the payload of the front blade and the RTM are powered up and are active.
  8. Tighten the top and bottom retention screws on the RTM face plate to secure the RTM in the slot.
  9. Plug the interface cable into the face plate connectors, if applicable.

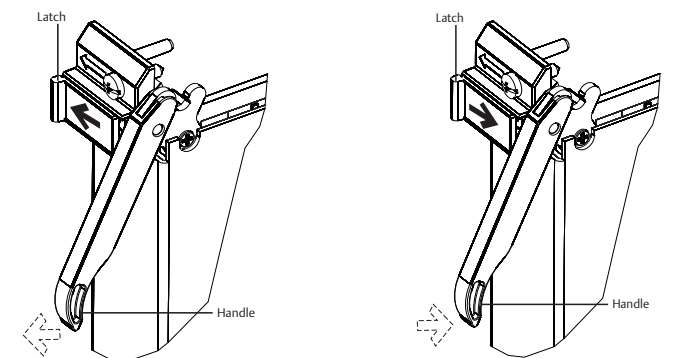
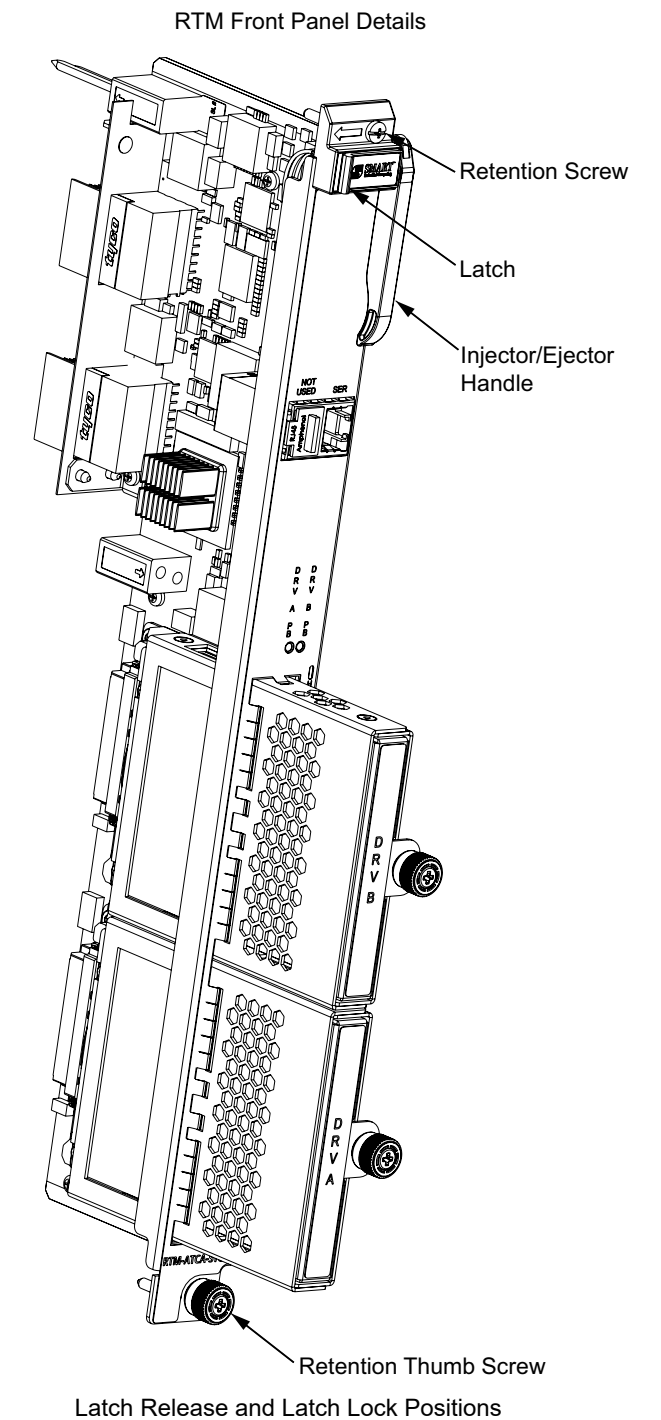

# 5 Install the RTM (no front blade installed)

### Notes:

- Use the following installation procedure when there is no front blade installed in the chassis. See Step 4 if a front blade is installed in the chassis.
  - The RTM-ATCA-STOR has two (2) NVMe U.2 drive carrier assemblies (DCAs) preinstalled in the module.
  - Refer to the diagram on the front page for the location of the latch, handle, retention screws and latch positions.
  - Refer to the SMART EC documentation for the corresponding front blade for detailed installation procedure.
1. Locate the slot where the RTM is to be installed, which must be the same slot as the corresponding front blade.
  2. Slide the top latch on the RTM module to the release position; the handle automatically raises outward.
  3. Carefully insert the RTM into the slot by placing the top and bottom edges in the card guides of the slot.
  4. Slide the RTM into the slot, applying equal and steady pressure to the RTM until you feel resistance.
  5. Continue to gently push the RTM into the slot until the RTM connectors engage.
  6. Fully insert the blade and then push the handle inwards. The latch automatically locks the handle.
  7. Tighten the top and bottom retention screws on the RTM face plate to secure the RTM in the slot.
  8. Insert the front blade into the corresponding slot on the front side of the chassis. For more information on installing the front blade, see the Installation and Use manual for the corresponding blade being used.
  9. As soon as the front blade is connected to the backplane, the blue LEDs on the front blade and the RTM lit up permanently. This indicates that the IPMC of the front blade and the MMC of the RTM are powered up.
  10. Close the handles of the front blade. The blue LEDs on the front blade and the RTM start flashing. This indicates that the front blade is informing the shelf manager that it wants to power up the payload of both the front blade and the RTM.
  11. Tighten the face plate screws on the front blade to secure the blade in the slot.

12. Wait until the blue LEDs on the front blade and the RTM are unlit. The blue LED when it is unlit indicates that the payload of the front blade and the RTM are powered up and are active.
13. Plug the interface cable into the face plate connectors, if applicable.

## Technical Assistance

For technical assistance or to report product damage or shortages, contact your local SMART Embedded Computing sales representative or visit <https://www.smartembedded.com/ec/support/>.

## Get More Information

For more information on this product, see the *RTM-ATCA-STOR Installation and Use* manual and other related technical documentation, which can be found by using the Documentation Search at <https://www.smartembedded.com/ec/support/>.

© 2021 SMART Embedded Computing™, Inc. All rights reserved. The stylized “S” and “SMART” is a registered trademark of SMART Modular Technologies, Inc. and “SMART Embedded Computing” and the SMART Embedded Computing logo are trademarks of SMART Modular Technologies, Inc. All other names and logos referred to are trade names, trademarks, or registered trademarks of their respective owners. These materials are provided by SMART Embedded Computing as a service to its customers and may be used for informational purposes only. For full legal terms and conditions, visit [www.smartembedded.com/ec/legal](http://www.smartembedded.com/ec/legal).